

EUROPEAN PATENT OFFICE

Patent Abstracts of Japan

PUBLICATION NUMBER : 08200456
 PUBLICATION DATE : 06-08-96
 APPLICATION DATE : 26-01-95
 APPLICATION NUMBER : 07030036

APPLICANT : JATCO CORP;

INVENTOR : SUMI YASUO;

INT.CL. : F16H 3/62

TITLE : PLANET GEAR TYPE TRANSMISSION

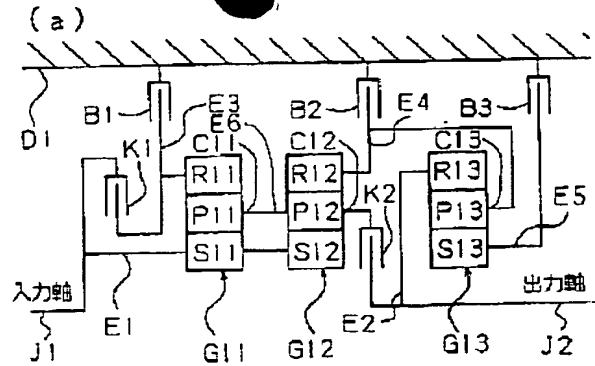

(b)

$$\alpha_1 = 0.375 \quad \alpha_2 = 0.70$$

$$\alpha_3 = 0.40$$

	K1	K2	B1	B2	B3	変速比	
1速		○	○			$\frac{1+\alpha_1}{\alpha_1}$	3.67
2速		○		○		$\frac{1+\alpha_2}{\alpha_2}$	2.43
3速		○			○	$1 + \frac{\alpha_3}{(1+\alpha_2)\alpha_2}$	1.41
4速	○	○				1	1.00
5速	○				○	$\frac{1}{1+\alpha_3}$	0.71
後退			○		○	$-\frac{1+\alpha_1}{\alpha_1 - \alpha_2 + \alpha_1\alpha_3 - \alpha_2\alpha_3}$	-3.02

ABSTRACT : PURPOSE: To reduce a loss by constituting a forward 5-speed shift and reverse 1-speed shift planet gear type transmission of three sets of planetary gears, three brakes and two clutches, and suppressing a rotational speed of all the rotary elements in an overdrive speed change shift.

CONSTITUTION: Sun gears S11, S12 of planetary gears G11, G12 are directly connected to an input shaft J1. Pinion gears P11, P12 are connected. A clutch K1 and a brake B1 are connected to a ring gear R11. In an accelerator constituted of a planetary gear G13 and a brake B3, rotation of a rotary member E4 is accelerated and output to an output shaft J2. In an overdrive speed change shift, the clutch K1 is connected to rotate the rotary member E4 integrally with the input shaft together with the planetary gears G11, G12. Accordingly, friction of a tooth surface in the planetary gears G11, G12 and wearing a bearing are stopped.

COPYRIGHT: (C)1996,JPO